

SECTINO

Security for Inter-Organizational Workflows

A Framework for the Modeling and Realization of
Security-critical Workflows in E-Government

Mag. Andrea Nowak

andrea.nowak@arcs.ac.at

<http://www.smart-systems.at>

- Motivation / Problem area
- Research Objectives
- Methodology
- Scenario in e-government:
"Municipal Tax Collection"
- Conclusion
- Outlook

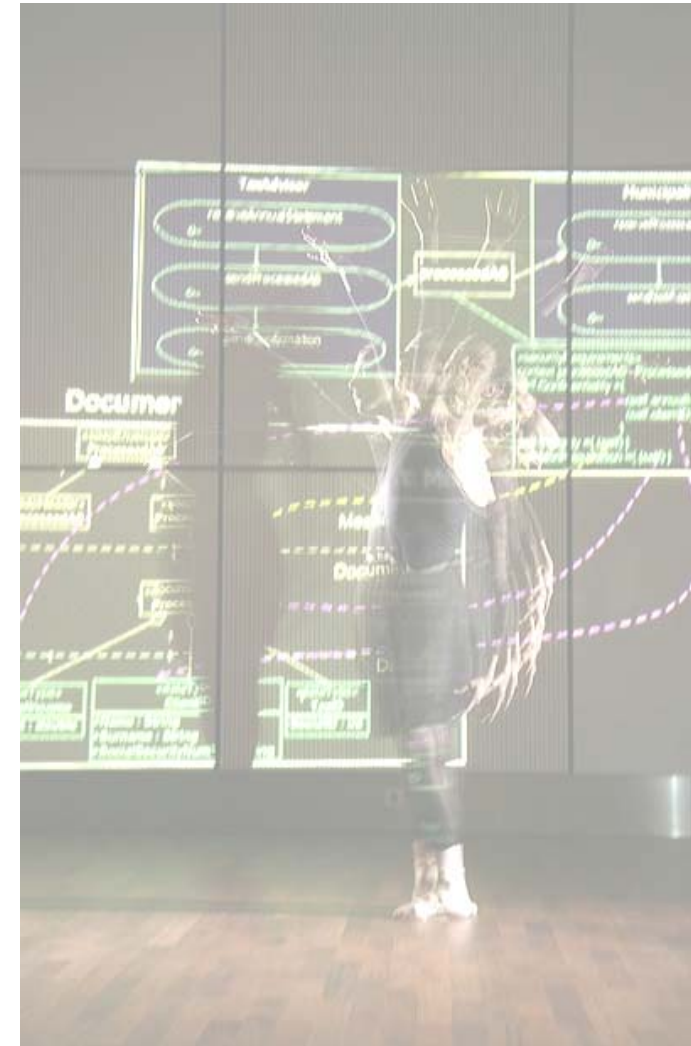

- B2B and eGovernment processes require
 - the coupling of internal workflows with external partners
 - adequate security management
- Web services centric architectures
 - permits the realization of inter-organizational workflows
 - build on platform independent standards as SOAP, WSDL, WS-Security
 - most security goals can technically be met
- But:
 - no guidance for the integration of security at application level
 - web service security standards are technology driven and very complex
 - Individual security can not be implemented
- Resulting in ad-hoc solutions
 - costly, complex
 - security requirements hard to manage (e.g., in changing scenarios)

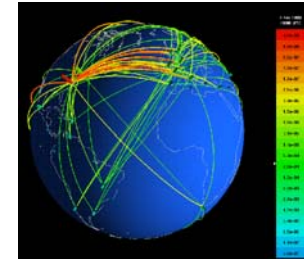

SECTINO

The development of a framework supporting the systematic realization and management of secure critical Inter-organizational workflows based on Web Services

- A METHOD
for the systematic design of security-critical, inter-organizational workflows
- A REFERENCE-ARCHITECTURE
for the implementation of secure workflows across domain boundaries
- A PROOF-OF-CONCEPT PROTOTYPE
that allows the transformation of the security requirements specified at the model level into executable artefacts for the configuration of the target reference architecture



“Model Driven Security”

Model Driven Security - extends the MDA approach

- models the security requirements in the Platform Independent Model (PIM)
- specifies the security infrastructure in the Platform Specific Model (PSM)
- map them onto each other

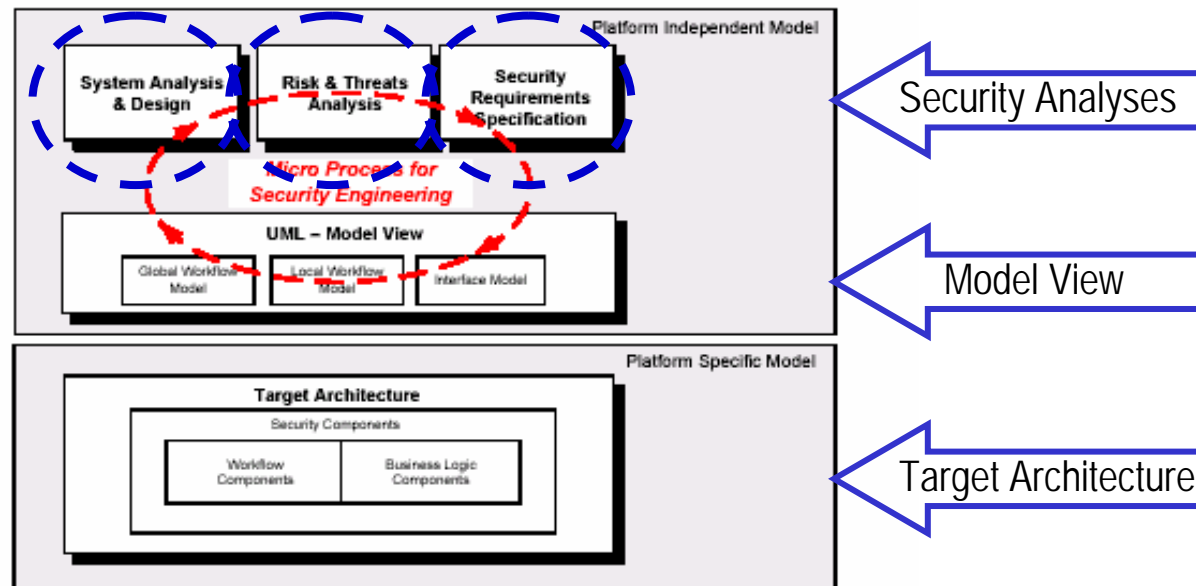

Model View -Workflow and Interface View

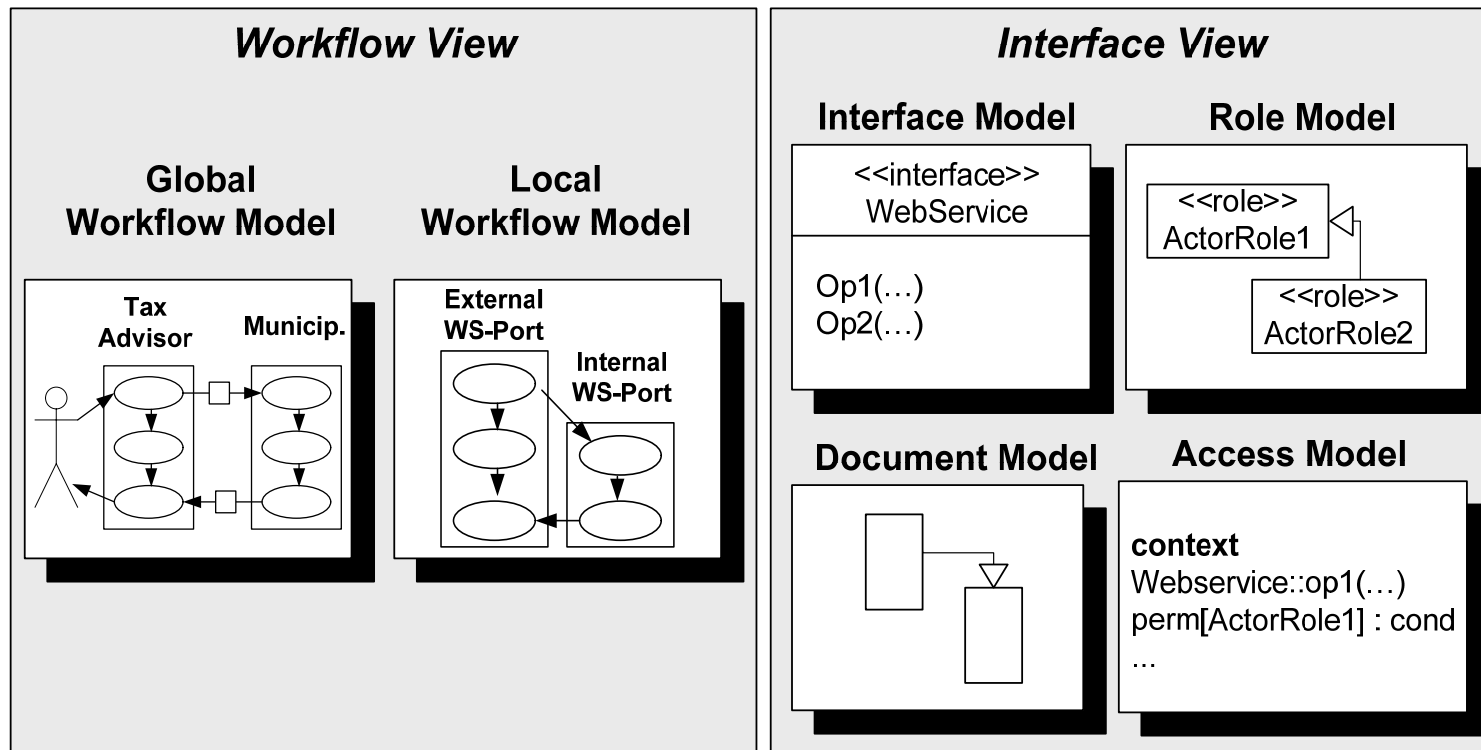

Target Architecture

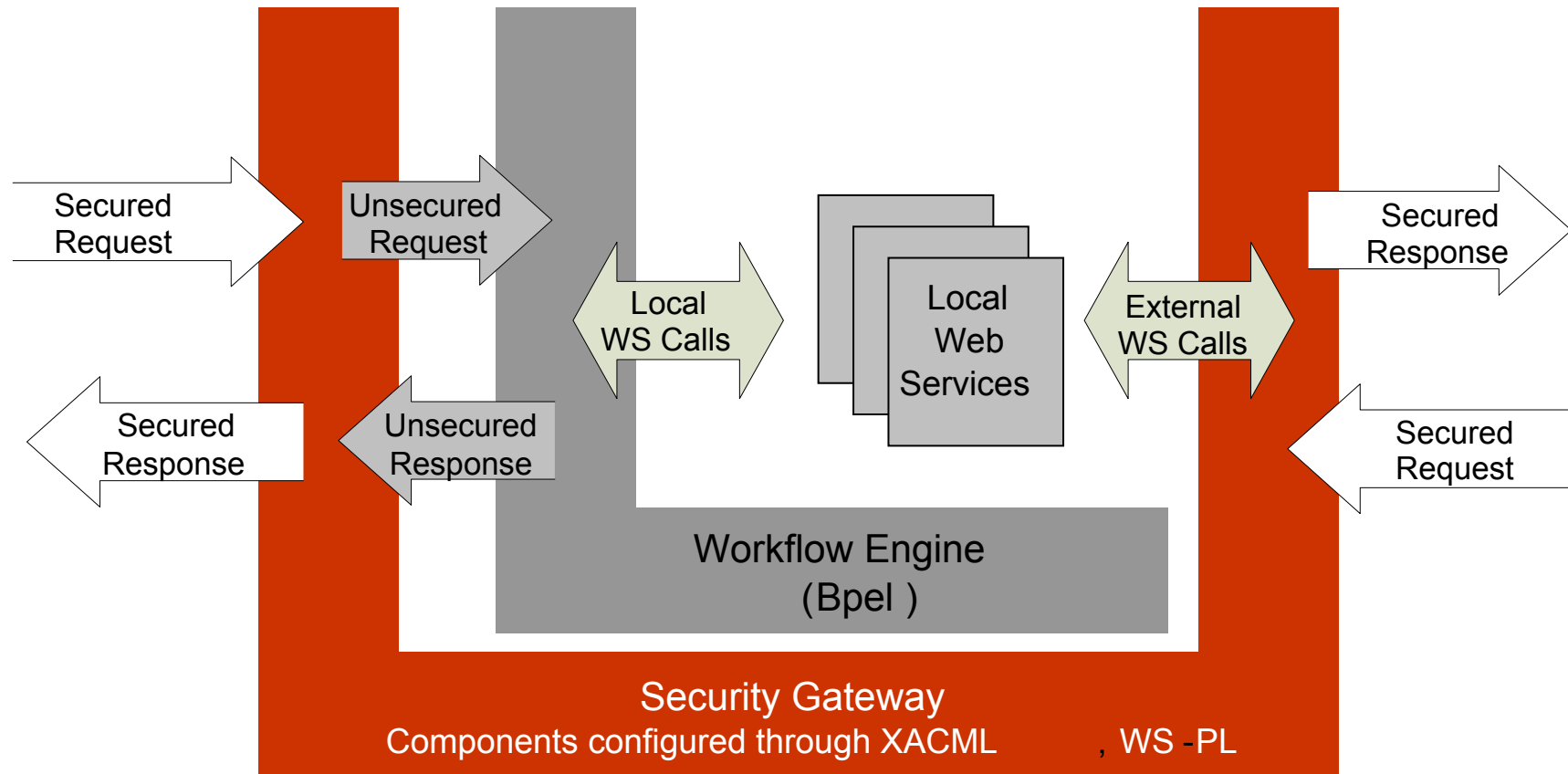

Model to Code Transformation

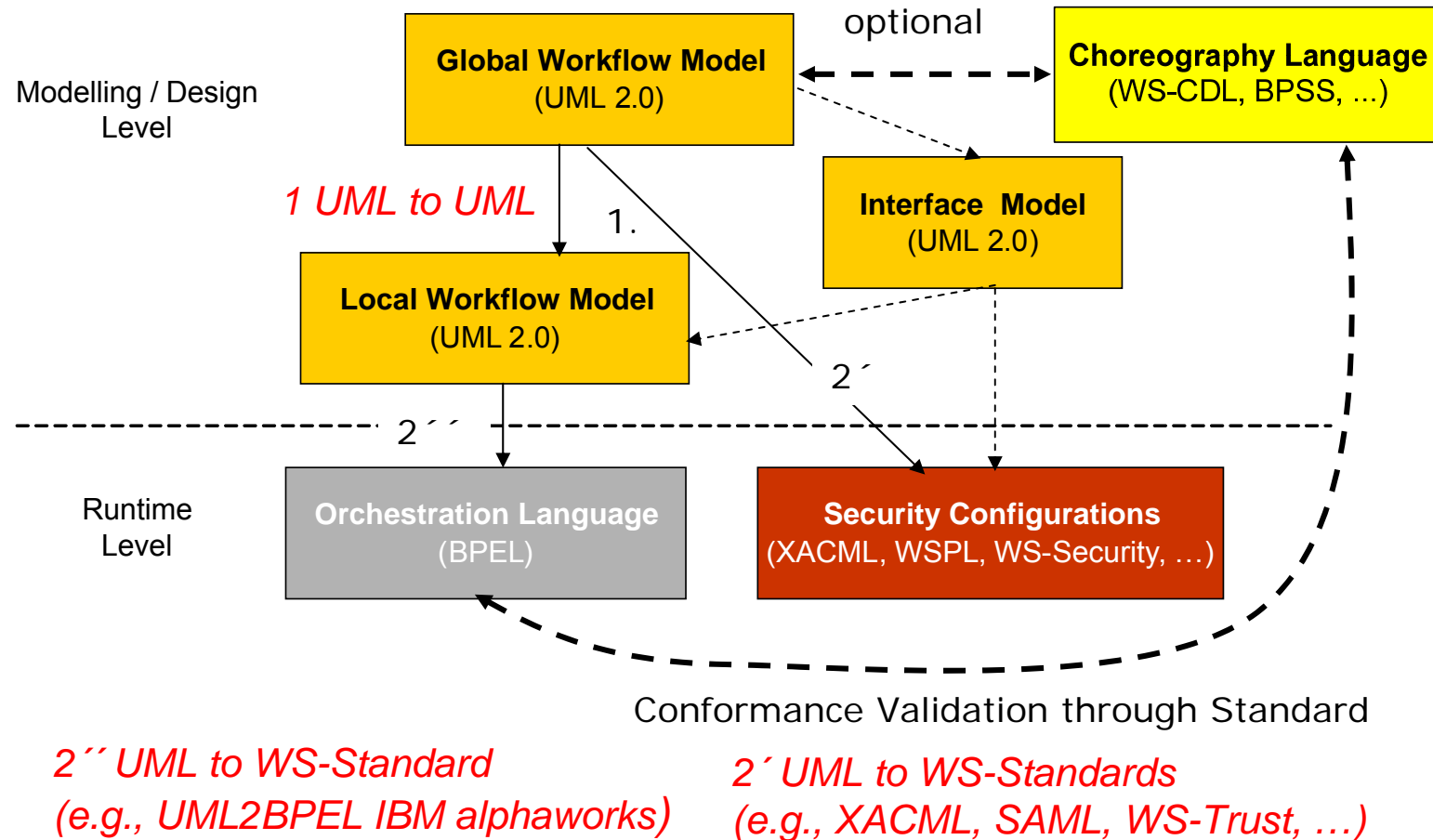

Model to Code Transformation

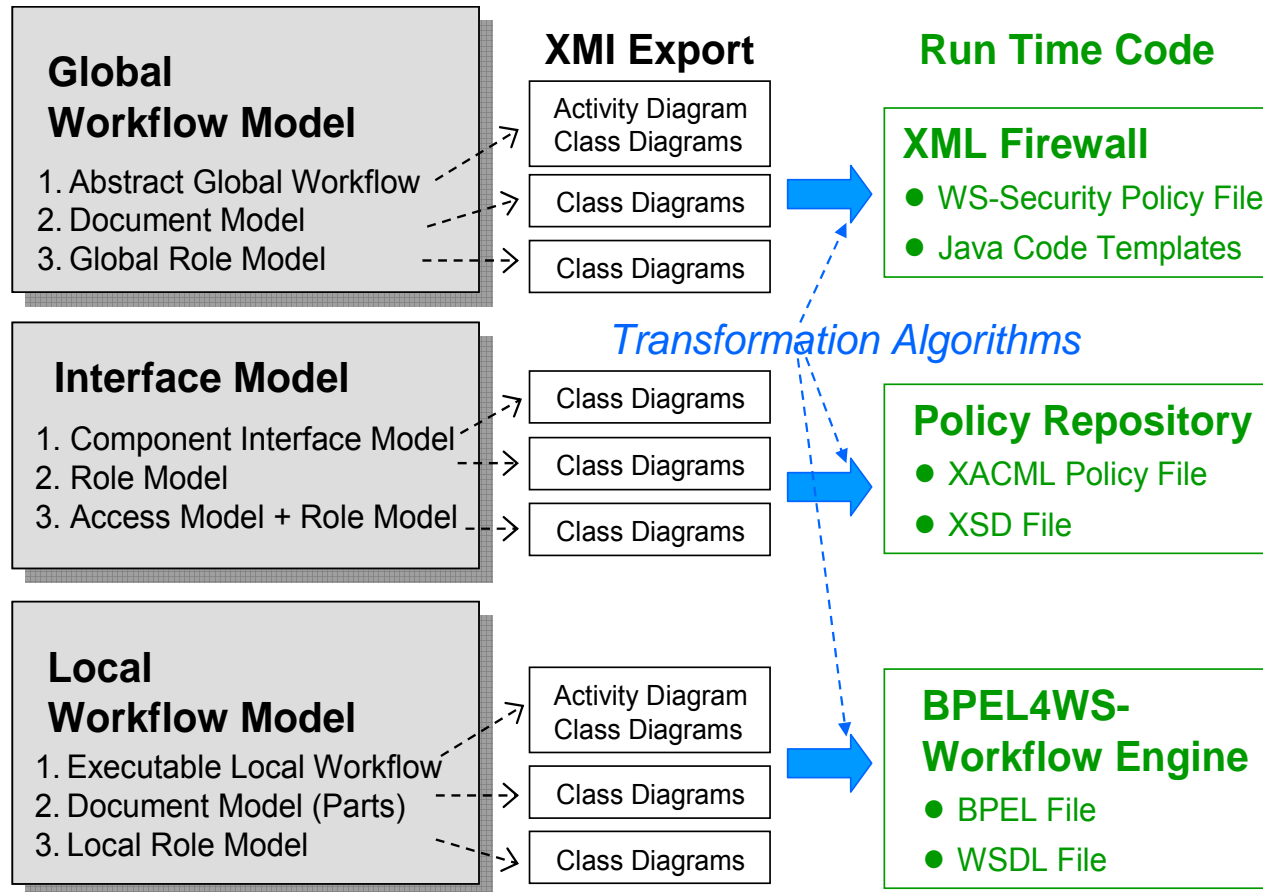

Municipal Tax Collection

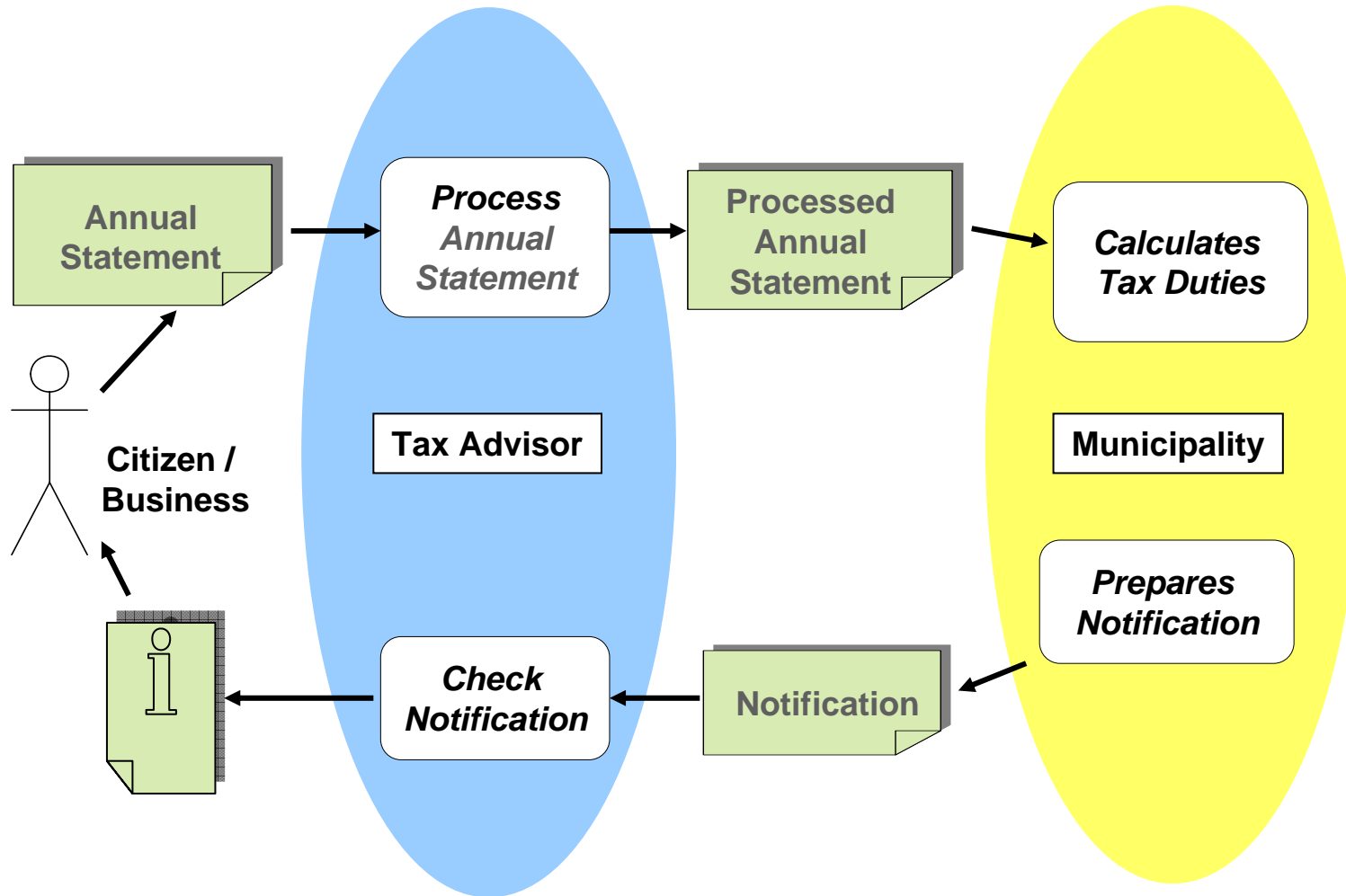

Workflow Description extended by security patterns

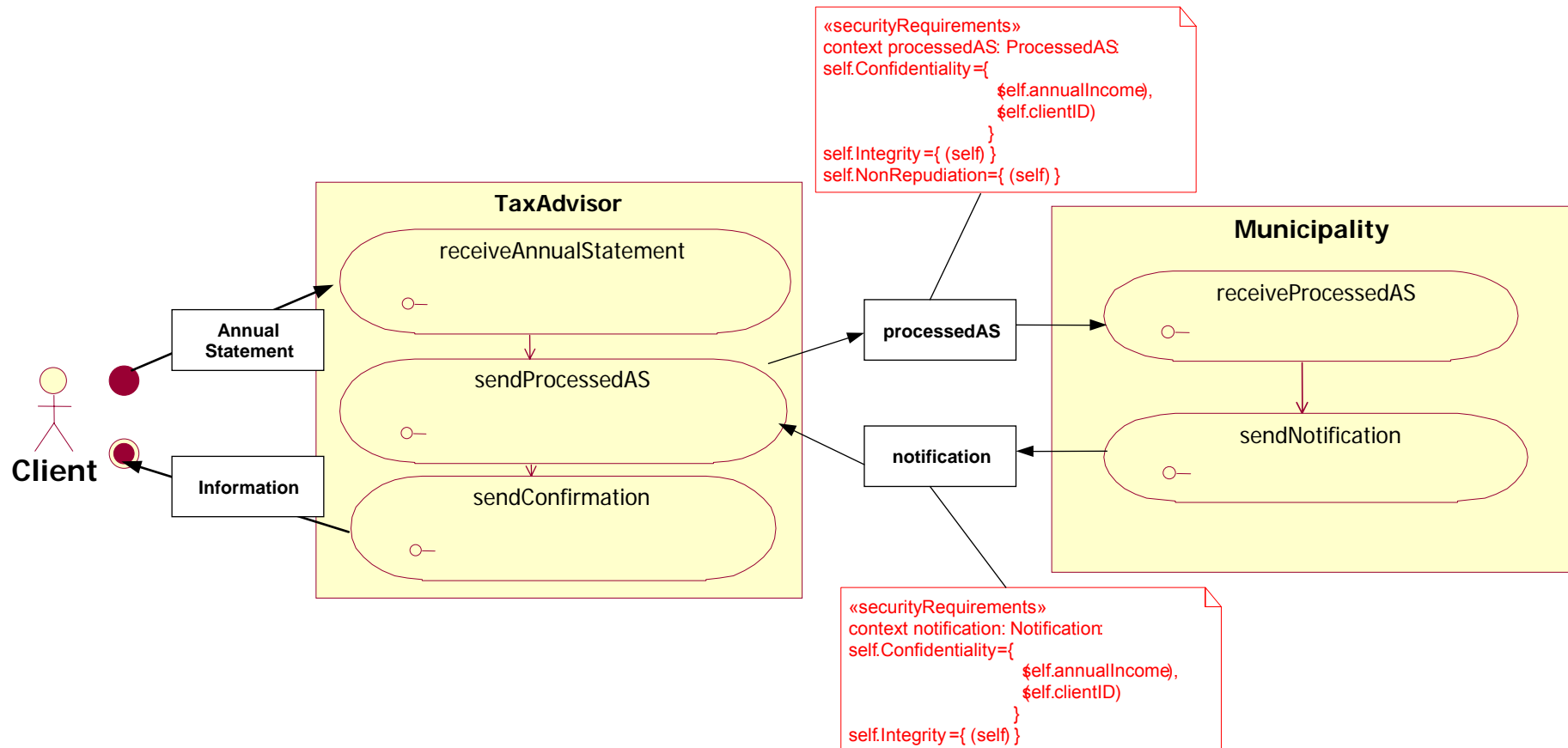

Relationship GWfM – Document Model

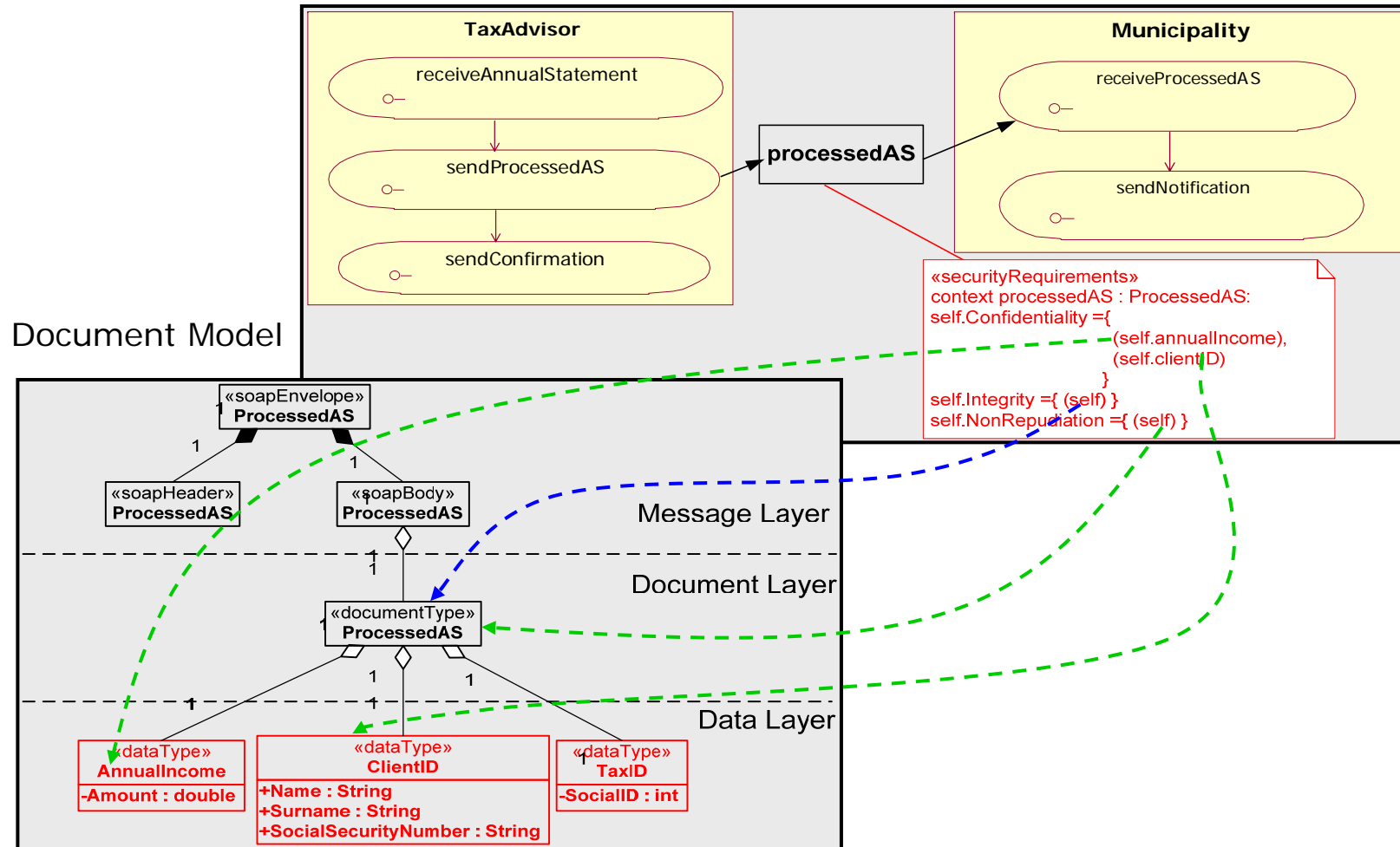

Implementation

- Implementation of SECTINO Workflows (global + local) based on ORACLE – BPEL (Java Libraries, Java Classes)
 - Specially Implementation of transformations algorithmic to bring the security requirements on the target reference architecture based on standards („SectinoUML2XACML“)
 - Input for Policy Repository
- Following framework components
 - PEP: XML-Security Gateway
 - PEP2PDP: XML configuration component contains all security requirements in an XML format
 - PDP (Policy Decision Point) for go or no go

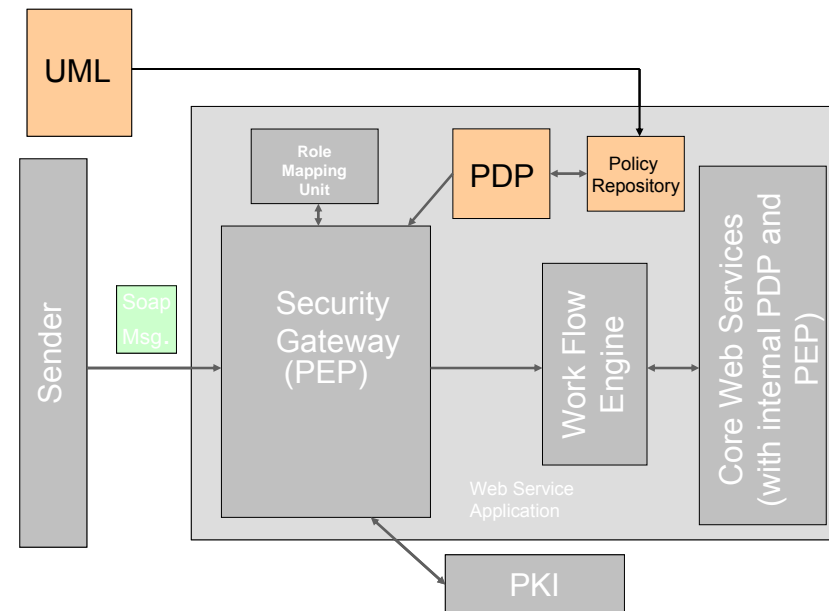

- Our method provides a framework for the rapid development of security-critical inter-organizational workflows; to be used by domain experts without specific technical knowledge
- Specification of security requirements is done at a very high level of abstraction
- Specification of security requirements are automatically translated into executable artifacts for the run-time architecture

Define the development method in an e-health environment

- Extension the set of supported security requirements (e.g. rights delegation, four-eyes principal)

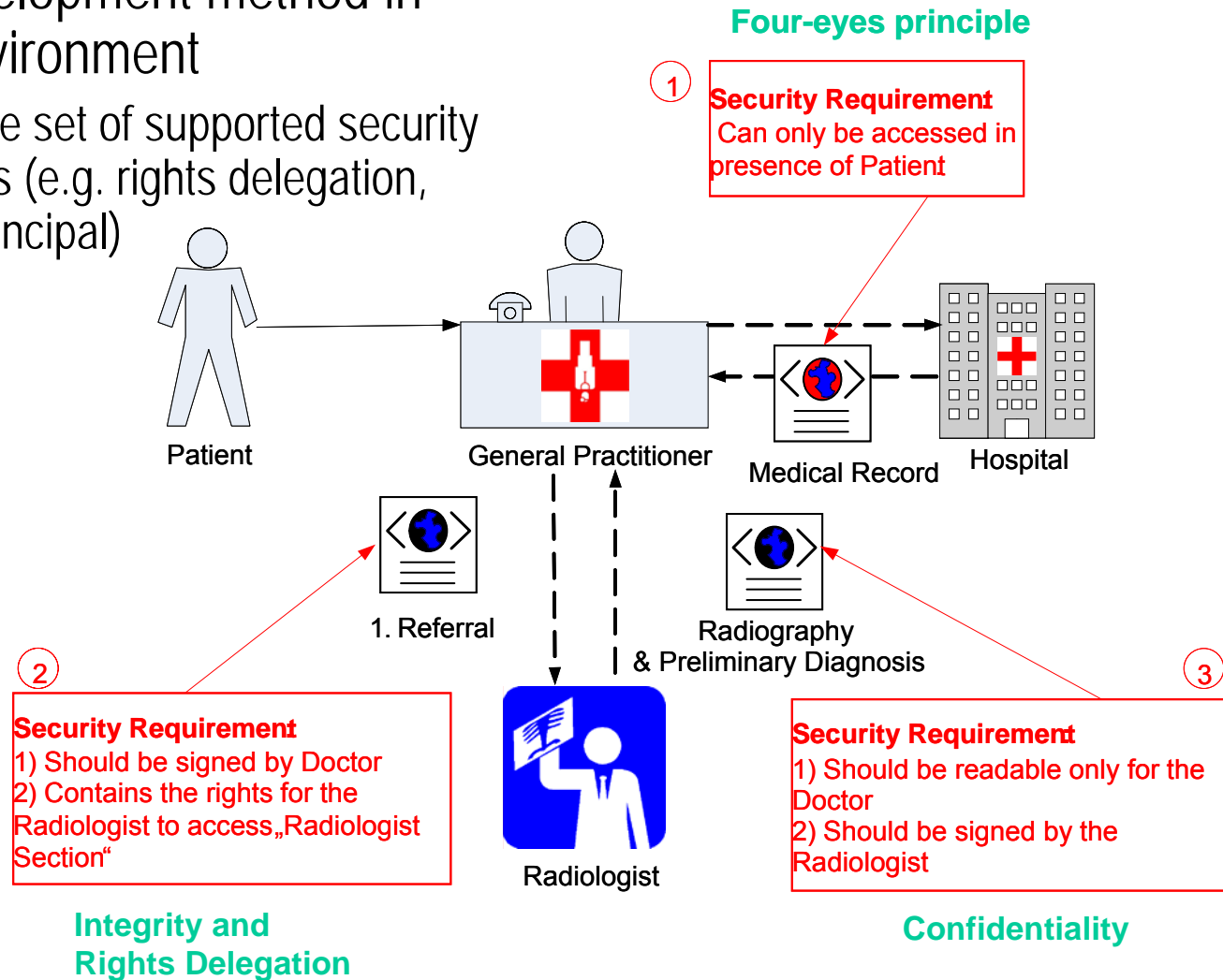



*Thank You for
Your Attention !*

